

MADDEN

ENGINEERED PRODUCTS

Centrifugal Boiler Blowdown Separators

Compact & Cost Effective
IN STOCK OPTIONS!



- Pg 1 Part Numbering Tree for BD Separator Vessels & Aftercoolers**
- Pg 2 Overview: Function, Purpose, Selection Guide**
- Pg 3 Features of Separators vs. Traditional Overflow Style Tanks**
- Pg 3 Predesigned Separators - Max Flow Rates & Required Cooling Water**
- Pg 4 Predesigned Separators - Dimensions, Selection Chart, Stock Options**
- Pg 5 Aftercooler Information - (Quenching System)**
- Pg 6 Fillable Specification Page**
- Pg 7 Typical P& ID**

PART NUMBERING TREE FOR B.D. SEPARATORS & AFTERCOOLERS

BD Separator Series	Inlet Size	Vent Size
BDS - (Bttm BD Separator) FTS - (Flash Tank Separator)	A - 3/4" NPT B - 1" NPT C - 1-1/4" NPT D - 1-1/2" NPT E - 2" NPT F - 2-1/2" NPT G - 3" Flg H - 4" Flg I - 6" Flg	1 - 1" FNPT 2 - 2" FNPT 2H - 2-1/2" FNPT 3 - 3" Flg 4 - 4" Flg 5 - 5" Flg 6 - 6" Flg 8 - 8" Flg
Diameter	Drain Size	Customization (---)
1 - 10" 2 - 16" 3 - 24" 4 - 30" 5 - 36" 6 - 42" 7 - 56"	1 - 1" FNPT 2 - 2" FNPT 2H - 2-1/2" FNPT 3 - 3" Flg 4 - 4" Flg 5 - 5" Flg 6 - 6" Flg 8 - 8" Flg	- If Applicable - S6 - 316SS material S4 - 304SS material NL - No legs HH - 4" x 6" hand hole 50 - BPVC 50 PSI 250 - BPVC 250 PSI (Standard is BPVC 150 PSI)
Seam to Seam Height		
____ - Enter inches		
Note for Drain & Vent -> <i>If spec'd threaded connection needs to be flanged, add "F" after the letter or number. Vice versa, if spec'd flanged connection needs to be threaded, add a "T" after the letter or number.</i>		

NOTES: Standard material is carbon steel. Standard BPVC is 150 PSI. Standard leg height is 30" for drains under 4", and 42" for drains 4" or larger. All units include inspection openings and SS centrifugal wear plates.

Ex.)	BDS230E66	---	(Custom)
------	-----------	-----	----------

Aftercooler Series	C.W. Inlet Size (& Reg. Vlv)	Regulating Valve Features
AC - Aftercooler, standard ACBT - AC w/elbow for BDT's	0 - 3/8" NPT 1 - 1/2" NPT 2 - 3/4" NPT 3 - 1" NPT 4 - 1-1/4" NPT 5 - 1-1/2" NPT 6 - 2" NPT 7 - 2-1/2" Flg D - Add "D" after number if using double seated valve design, opposed to Sterling single seat.	9 - 9" x 3/4" sensing probe 13 - 13" x 1" sensing probe BW - Brass thermowell (if app.) SW - SS thermowell (if app.)
Diameter of AC Pipe		AC Pipe Connection
20 - 2" 2H - 2-1/2" 30 - 3" 40 - 4" 50 - 5" 60 - 6"		T - MNPT F - Class 150 RF Flg FF - Class 300 RF Flg

NOTE (CW Regulating Valve P/N's): This part number tree can be used for standalone cold water regulating valves as well. All P/N's for valves only start with "AC10____", then add the relevant information from center and right column.

EX.)	AC404D	---	9F
------	--------	-----	----

Centrifugal Blowdown Separators

Function: Madden Blowdown separators are designed to immediately dispose of hot, high pressure boiler blowdown. When the hot, high pressure bottom blowdown from the boiler enters the separator's low pressure vessel, flash steam is created and vented to the atmosphere. The remaining hot bottom blowdown drains out the vessel to the aftercooler. A temperature regulating valve on the aftercooler opens a cooling water valve. This results in the immediate mixing of cold water and the hot bottom blowdown to a temperature $\leq 140^{\circ}$ Fahrenheit.

Selection Guide: To select the proper blowdown separator for your application, you need to know both the boiler operating pressure and the size of the bottom blowdown connection. Using those two figures, you can match the bottom blowdown inlet on the blowdown separator to the boiler blowdown connection size from the table on page 2. For example, the proper blowdown separator connection for a 125 psi boiler with a 1-1/2" bottom blowdown connection, you'll need model number BD230D45. The aftercooler size is determined by the size of the drain in the blowdown separator. The temperature regulating valve sizing is dependent on the cold water inlet on the aftercooler selected. For sizing on blowdown tanks, or for blowdown separators for boilers over 300 psi, contact the factory. All connections 2-1/2" and smaller are NPT, 3" and larger are 150 psi RF flanged. These are the standards, customized connections available upon request.
See page 3 for system drawing and dimensions.

Data Required: Blowdown Pipe Size: _____ Boiler Pressure: _____ (PSIG)

Traditional Blowdown Tanks

Function: Blowdown Tanks are used as an alternative system for cooling the bottom boiler blowdown. These large tanks retain the blowdown water volume from one blow after the flash steam has been vented to the atmosphere and allow the water to cool down by natural convection over a 6-12 hour period. This retained water that did not reach the tank's overflow drain will be close to room temperature when it is displaced by the next blowdown. The resulting mixture of retained water and new blowdown entering the tank will be $\leq 140^{\circ}$ Fahrenheit as it is displaced out of the overflow drain.

See separate data sheet, "BD_Tank-DataSheet_V1.0" for more information on what all Madden can offer for traditional bottom blowdown tanks.

Selection Guide: To select the proper blowdown tank for your application you need to know the following:

1. Boiler operating pressure.
2. Size and type of the bottom blowdown connection.
3. Equivalent pipe length to the tank.
4. And the boiler's steam drum diameter and length.

Contact the factory for assistance.

Features of Blowdown Separators & Tanks

Blowdown separators and tanks are made to ASME Div 1, Sec VIII code. Separators are designed to 150 PSI – 0-500 deg F. Tanks are designed 50 PSI – 0 to 450 deg F. These vessels will come with a U-1 form and are assigned a National Board serial number.

Blowdown Separators

- Fast, safe, low-cost way to separate steam and water to remove harmful dissolved solids from the boiler(s).
- Protects the boiler(s) surfaces from severe scaling and/or corrosion problems as a result.
- Quiet design keeps noise levels below 90 dBA. No exhaust head required.
- Cools bottom boiler blowdown to safe temperatures to meet state and local requirements.
- Vortex breaker and SS triangular baffle reduce momentum of water before drain and ensures flash steam separation from condensate. Drain is completely filled - no center void
- Compact design saves floor space. Design also gravity drains for added service life.
- *AVAILABLE IN 304SS UPON REQUEST.*

Blowdown Tanks

- Designed around the latest NB-27 standards.
- Other design standards and codes can be met upon request.
- Cools bottom boiler blowdown to safe temperatures to meet state and local requirements.
- Best design choice for boilers operating above 300 psig.
- Uses natural convection to cool intermittent bottom boiler blowdown, installation of other cooling accessories not needed.
- Saves on plant water usage.
- Tangential inlets help separate steam from condensate.
- Wear plates available in CS and SS.
- *AVAILABLE IN 304SS UPON REQUEST.*

Blowdown Flow Rates and Required Cooling Water

Madden offers two sets of pre-designed centrifugal blowdown separators. The BD130 and BD230 models are pre-sized for boilers operating up to 150 PSIG. The BD242 models are sized for boilers operating between 151 and 300 PSIG. Reference the below Table 1. The maximum blowdown flow rate assumes ~30 ft. of equivalent straight length of Sch 80 pipe from boiler to separator.

Table 1 - Blowdown Separator Design Parameters

Blowdown Separator Model #	Vessel Blowdown Inlet	Maximum Blowdown Flow (PPH)	Resulting Flash Steam (PPH)	Resulting Condensate (GPM)	Required Quenching Flow (65 deg F.) (GPM)	Required C.W. Regulating Valve Size
Predesigned for Boilers Operating Between 15 - 150 psig.						
BDS130A22	3/4"	15,000	2,460	25.04	23.92	3/4"
BDS130B23	1"	18,000	2,952	30.05	28.86	3/4"
BDS230C44	1-1/4"	35,000	5,740	58.44	56.32	1" (D)
BDS230D45	1-1/2"	57,500	9,430	96.00	92.37	1-1/4" (D)
BDS230E66	2"	100,000	16,400	166.96	160.77	1-1/2" (D)
Predesigned for Boilers Operating Between 151 - 300 psig.						
BDS242B34	1"	29,500	6,667	45.60	43.84	1"
BDS242C46	1-1/4"	58,000	13,108	89.65	86.38	1-1/4" (D)
BDS242D56	1-1/2"	83,000	18,758	128.30	123.32	1-1/2" (D)
BDS242E68	2"	152,000	34,352	234.96	228.67	2" (D)

Note: Cold water regulating valve sizes with "D" denotes a double seated design opposed to single seat design.

Blowdown Separator: Dimensions & Connections

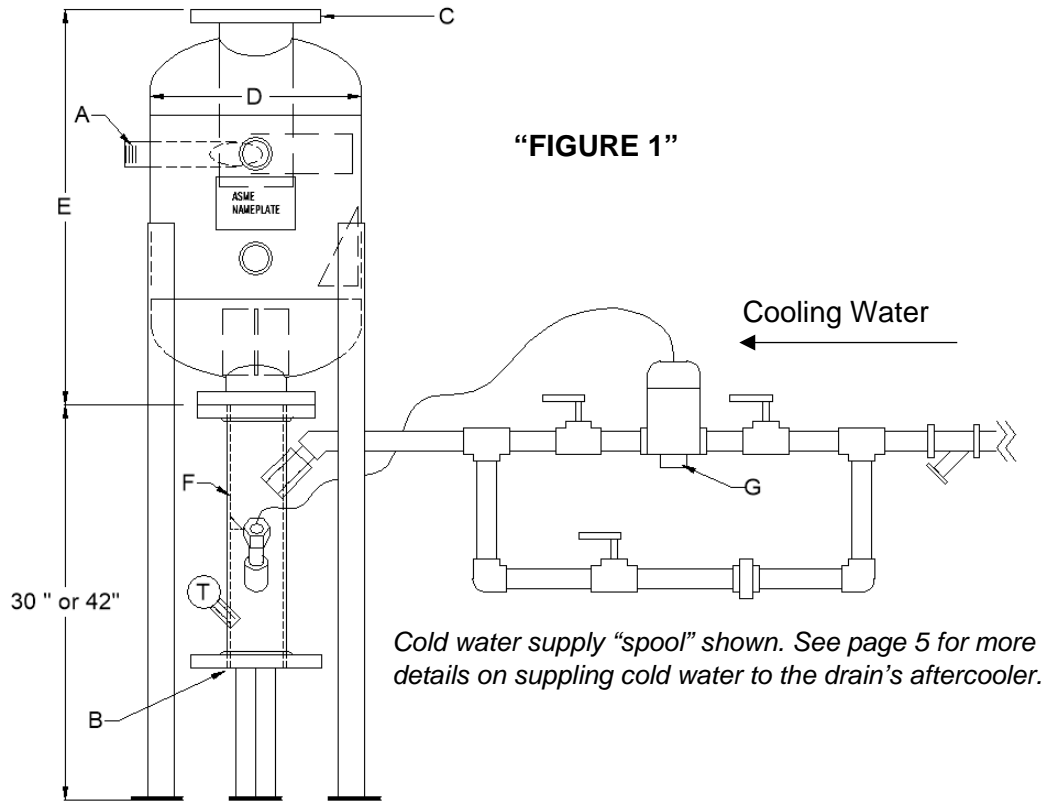

Table 2 - Predesigned Blowdown Separator Sizing Selection Chart

Blowdown Separator Model #	Blowdown Inlet -A-	Drain -B-	Vent -C-	Vessel Dia. x H (-D x E-)	Aftercooler Part No. -F-	Cold Water Inlet	After Cooler Size	C.W. Valve Number	Valve Size -G-
Predesigned for Boilers Operating Between 15 - 150 psig.									
BDS130A22	3/4"	2-1/2"	2-1/2"	10" x 30"	AC2H2	3/4"	2-1/2"	AC102	3/4"
BDS130B23	1"	2-1/2"	3"	10" x 30"	AC2H2	3/4"	2-1/2"	AC102	3/4"
BDS230C44	1-1/4"	4"	4"	16" x 30"	AC403D	1"	4"	AC103D	1" (D)
BDS230D45	1-1/2"	4"	5"	16" x 30"	AC404D	1-1/4"	4"	AC104D	1-1/4" (D)
BDS230E66	2"	6"	6"	16" x 30"	AC605D	1-1/2"	6"	AC105D	1-1/2" (D)
Predesigned for Boilers Operating Between 151 - 300 psig.									
BDS242B34	1"	3"	4"	16" x 42"	AC303	1"	3"	AC103	1"
BDS242C46	1-1/4"	4"	6"	16" x 42"	AC404D	1-1/4"	4"	AC104D	1-1/4" (D)
BDS242D58	1-1/2"	5"	8"	16" x 42"	AC505D	1-1/2"	5"	AC105D	1-1/2" (D)
BDS242E68	2"	6"	8"	16" x 42"	AC606D	2"	6"	AC106D	2" (D)
STOCKED DESIGNS									
Most jurisdictions do not permit reducing the boiler's integral blowdown connection size until after passing through a flash tank. For this reason, Madden's stock designs have 2" inlets (you can always 'bush up', but not down).									
BDS130E23	2"	2-1/2"	3"	10" x 30"	AC2H_	(TBD)	2-1/2"	(TBD)	(TBD)
BDS230E44	2"	4"	4"	16" x 30"	AC40_	(TBD)	4"	(TBD)	(TBD)
BDS230E66	2"	6"	6"	16" x 30"	AC60_	(TBD)	6"	(TBD)	(TBD)
Note 1: Standard connection types are NPT for 3" or less, and Class 150 Flange for > 4".									
Note 2: Custom vessels are available upon request.									

Automatic Aftercooler Information

Function: The automatic aftercooler is used to quench the remaining condensate to a safe temperature for sewer disposal after flashing off steam. The design temperature to be reached after quenching is 140 deg F or less. Aftercoolers utilize three main components to achieve adequate quenching:

1. **Aftercooler:** A-53 SCH 40 Pipe installed on drain of blowdown separator with a stainless steel baffle inside to help mix cold water with hot condensate.
2. **Temperature Regulating Valve & Sensing Bulb:** A self-operating temperature regulating valve is provided with the aftercooler. The valves are sized with the assumption 65 deg cooling water is available. These valves include a temperature sensing bulb with gases that expand to open the valve spring when the blowdown passes over. The standard available quenching temperature set range is 60 - 140 deg F.

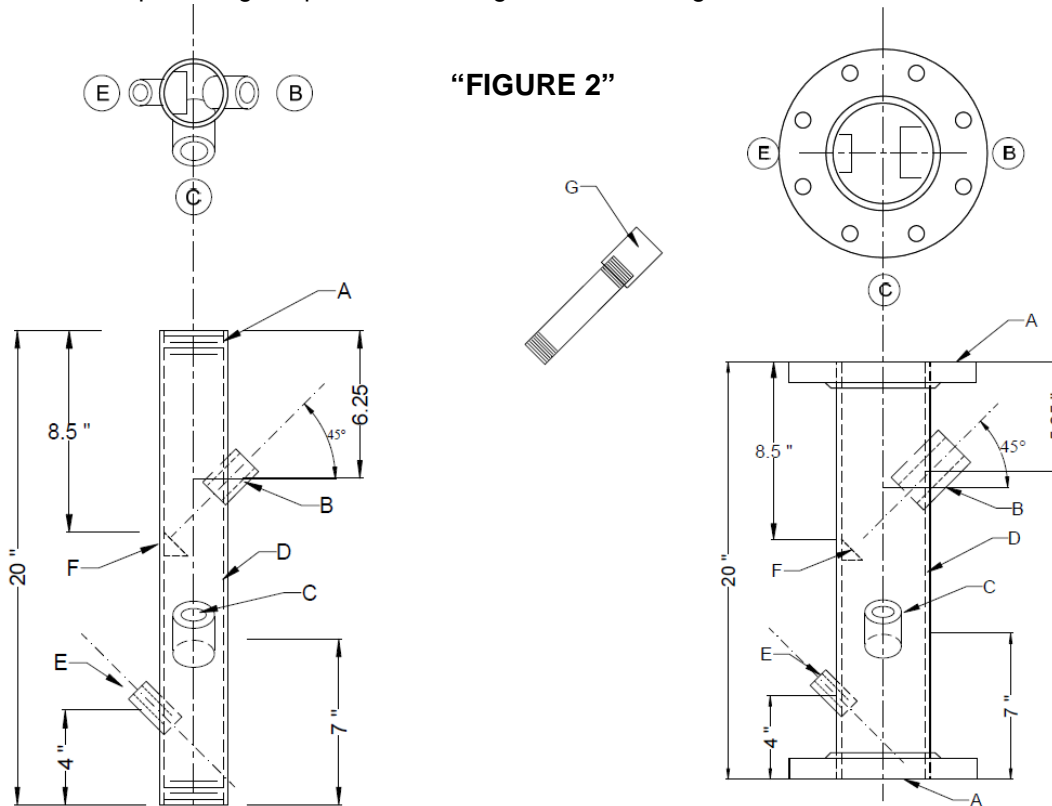

“A” – Inlet and outlet connection. MNPT for 2” and 3”, Class 150 RFSO for 4” and up.

“B” – Cooling water inlet connection, Class 150 C/S coupling, sized the same as selected regulating valve.

“C” – Regulating valve sensing probe connection. 1” FNPT Class 150 C/S coupling.

“D” – Aftercooler pipe, A53, seamless. 304SS available as requested option.

“E” – Temperature gauge connection, ½” FNPT, Class 150 C/S.

“F” – SS water deflector. Helps ensure cooling water will mix efficiently with hot condensate.

“G” – Pipe nipple and coupling used when needed for certain cold water regulating valve sensing probes.

COLD WATER SUPPLY EQUIPMENT (Ref. Fig. 1): Madden can also supply additional pipe, fittings and valves for the cold water supply to the regulating valve and aftercooler. There are two design types:

1. **LINE** - Recommended for intermittent cooling processes: A cold water supply “line” will include a Y-strainer, aforementioned temperature regulating valve, a union, and check valve. Madden will provide the remaining piping to complete the line and install on the aftercooler at our factory.
2. **SPOOL** - Recommended for continuous cooling processes: A complete cold water supply “spool” includes a bypass line should maintenance of the regulating valve ever be required. Reference “Figure 1” on page 3 for layout. These include a Y-strainer, aforementioned temperature regulating valve, 2 gate valves to isolate regulating valve, a globe valve on the bypass line to control cold water supply manually, and a check valve.

Blowdown Separator: Specification Sheet

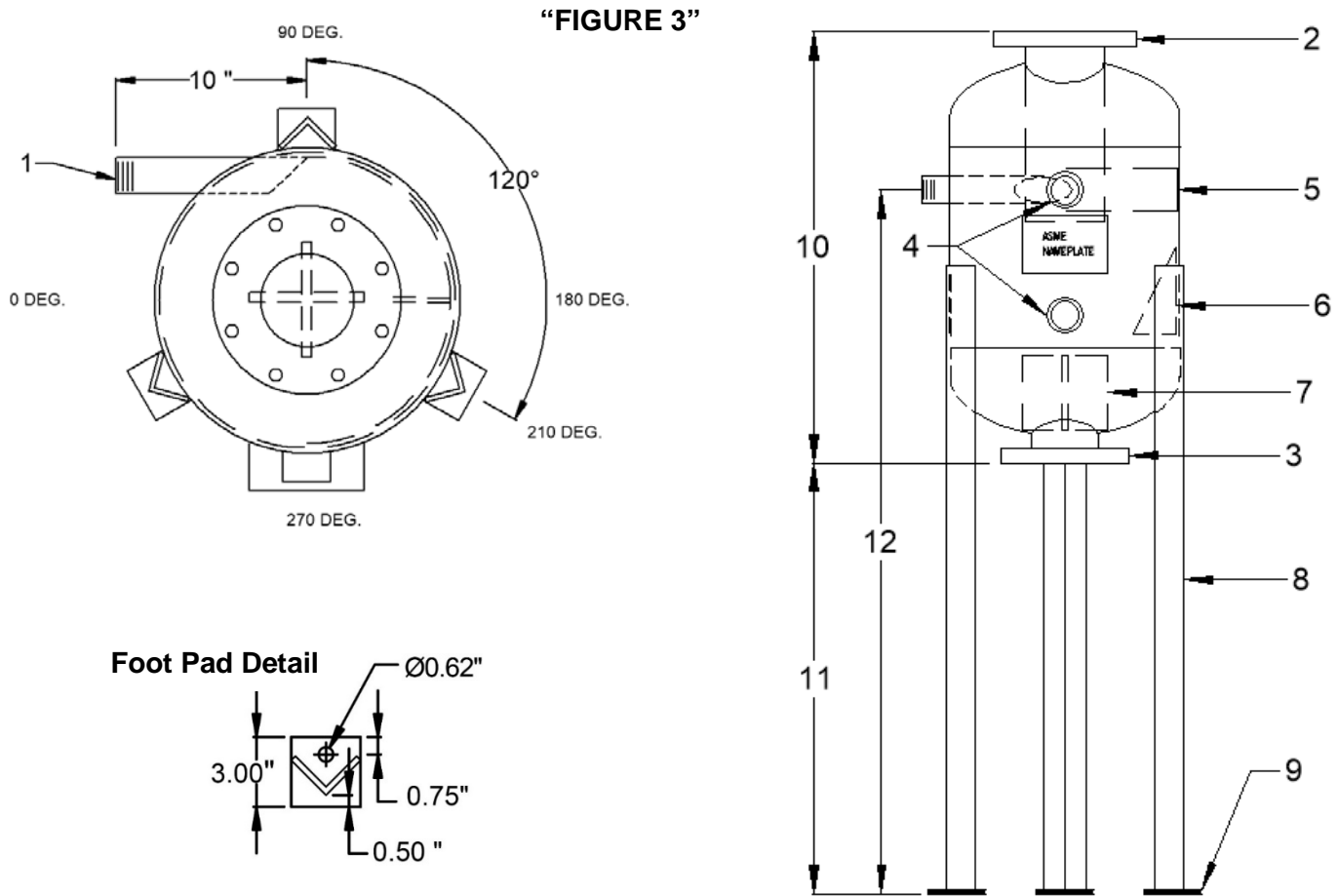

LEG HEIGHT: For drain sizes less than or equal to 3", 30" leg height will suffice. For drain sizes 4" and larger, 42" leg height is recommended for easier installation of an elbow fitting (if needed).

Item	Description	Item	Description
#1	_____ " NPT Blowdown Inlet Connection	#7	Vortex Breaker, Stainless Steel
#2	_____ " Vent Connection, 150 psi R.F. Flange	#8	Legs with Foot Pad
#3	_____ " Drain Connection, 150 psi R. F. Flange	#9	Foot Pad (see details above)
#4	2" NPTF Inspection Opening	#10	Vessel Height: ____ 30" or ____ 42"
#5	Impingement Plate, Stainless Steel	#11	Leg Height: ____ 30" or ____ 42"
#6	Wall Baffle, Stainless Steel	#12	Inlet Height: ____ 37" or ____ 49"

Typical P&ID for Intermittent Bottom Blowdown Separators

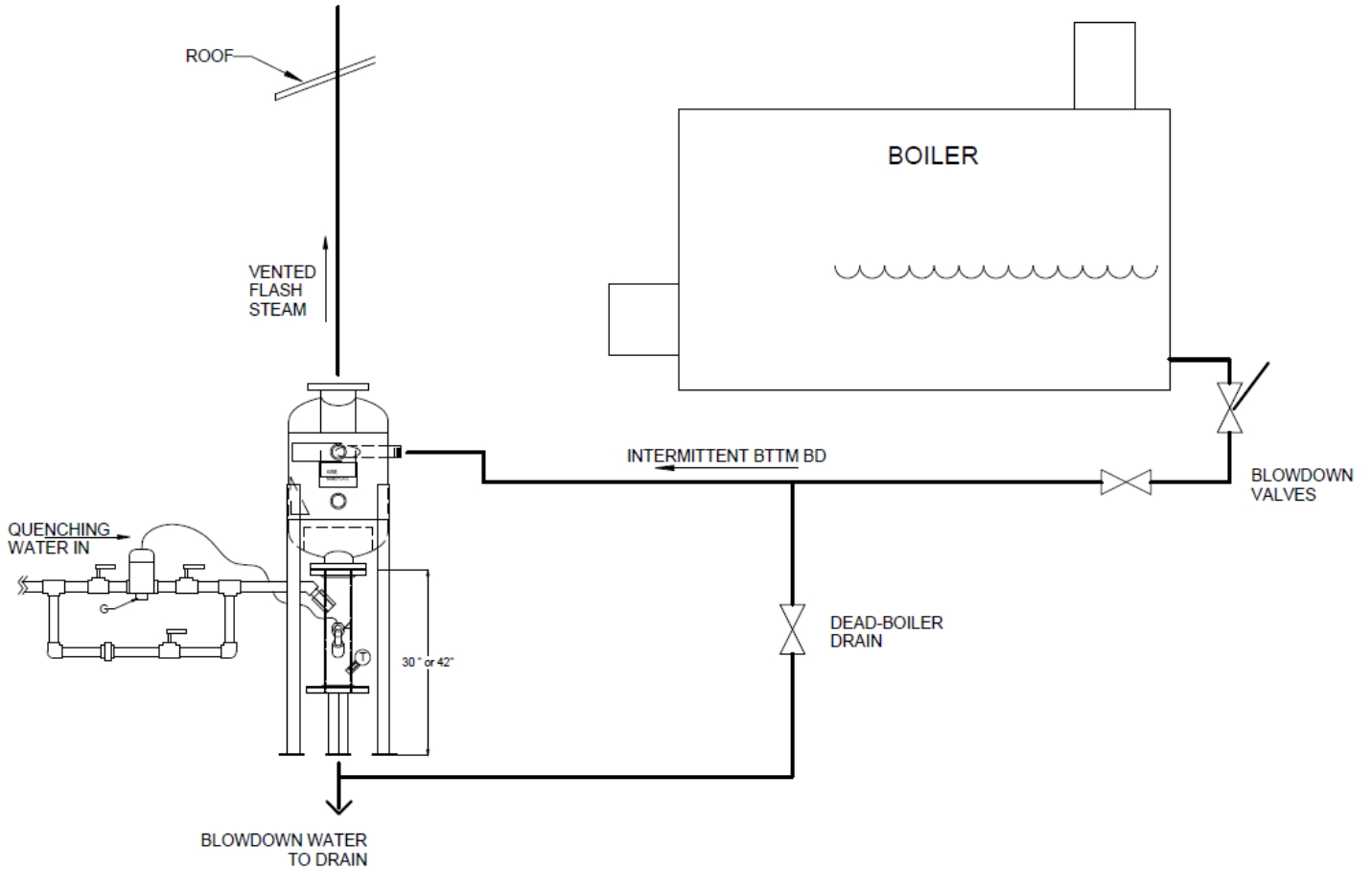

MADDEN
ENGINEERED PRODUCTS

1317 Princeton Blvd., Elkhart, Indiana
Phone: (574) 295-4292
Fax: (574) 295-7562
Email: info@maddenep.com

SOLD BY: